

# Temperature Transmitter

## Product Manual

This document applies to products of batch **AA** and onwards (TT 01 20 **AA** 00001). See chapter 2.

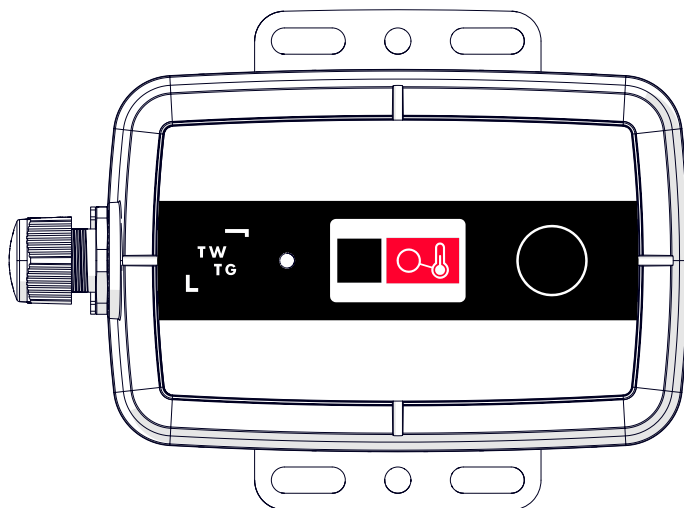



## Contents

<b>1</b>	<b>TWTG NEON</b>	<b>4</b>
1.1	NEON Product Introduction . . . . .	4
1.2	Related Documents . . . . .	4
<b>2</b>	<b>Getting started</b>	<b>5</b>
2.1	Compatibility of this manual . . . . .	5
2.2	What you will need . . . . .	5
2.3	What is in the box . . . . .	5
2.4	Product Specifications . . . . .	6
2.5	Product Type Identification . . . . .	8
2.6	Component Names . . . . .	9
2.7	Product Dimensions . . . . .	10
<b>3</b>	<b>Warnings</b>	<b>11</b>
3.1	ATEX / IECEx . . . . .	11
3.1.1	Specific Conditions of Use . . . . .	11
3.1.2	Installation . . . . .	11
3.1.3	Operation . . . . .	11
3.1.4	Service . . . . .	11
3.1.5	Output parameters . . . . .	12
3.2	General . . . . .	12
3.2.1	Transport and Storage . . . . .	12
3.2.2	Warranty . . . . .	12
3.2.3	Warranty will be void in case of . . . . .	12
<b>4</b>	<b>Provisioning</b>	<b>13</b>
4.1	User Interface . . . . .	13
4.2	Operating the Device . . . . .	14
4.2.1	Read device status . . . . .	14
4.2.2	Device Activation . . . . .	15
4.2.3	Device Deactivation . . . . .	16
4.3	Product Identification . . . . .	17
4.3.1	NFC . . . . .	17
4.3.2	Data Matrix Code Code . . . . .	17
<b>5</b>	<b>Installation</b>	<b>18</b>
5.1	Precautions . . . . .	18
5.2	Mounting Bracket Dimensions . . . . .	18
5.3	Installation Methods . . . . .	19
5.3.1	Installation using mounting holes . . . . .	19
5.3.2	Installation using threaded holes . . . . .	19
5.3.3	Installation using bandclamp . . . . .	20
5.4	Using the Temperature Transmitter with Thermocouples . . . . .	21
5.4.1	Cold Junction Compensation . . . . .	21
5.4.2	Assessed connectors . . . . .	21
5.4.3	Selecting a thermocouple wire . . . . .	21
5.4.4	Connecting a thermocouple wire to the temperature interface . . . . .	22
5.5	Using the Temperature Transmitter with a RTD (3-wire) . . . . .	23
5.5.1	Connecting a RTD (3-wire) sensor to the temperature interface . . . . .	23

---

<b>6</b>	<b>Product Functionalities</b>	<b>24</b>
6.1	Application Event Message . . . . .	24
6.1.1	Event-triggers . . . . .	24
6.1.2	Content application event message . . . . .	25
6.2	Device Status . . . . .	25
6.3	Default Configuration . . . . .	25
<b>7</b>	<b>Maintenance</b>	<b>26</b>
7.1	Battery Replacement . . . . .	26
7.1.1	Battery Specifications . . . . .	26
7.1.2	Required tools . . . . .	26
7.1.3	Disassembly of device . . . . .	27
7.1.4	Built in Self-Test Procedure . . . . .	28
7.1.5	Assembly of device . . . . .	29
<b>8</b>	<b>Accessories &amp; Spare Parts</b>	<b>31</b>
<b>9</b>	<b>Declaration of Conformity</b>	<b>32</b>

# 1 TWTG NEON

## 1.1 NEON Product Introduction

NEON stands for a standardised approach to collecting data points from the operational environment and in doing so , creates a general approach to integrated solutions within existing IT ecosystems.

The TWTG NEON product range supports all industrial customers moving towards LoRaWAN as the Industrial IoT network of the future.

The LoRaWAN network gives industrial operations a secure solution, which scales-up to tens of thousands of sensors, covers complete sites with only a small amount of gateways and best of all – the low-power approach means that the lifetime of the NEON products can be extended dramatically.

## 1.2 Related Documents

Document Name	Document Number
NEON Data Sheet	6015_P20-002_Data-Sheet-NEON-Temperature-Transmitter
NEON Communication Protocol	6020_AB_Communication-Protocol-NEON-Temperature-Transmitter

**Table 1:** Related documents

## 2 Getting started

### 2.1 Compatibility of this manual

This manual is meant to be used with products of from a specific production batch. See [Serial Number](#) for an explanation on how to retrieve the production batch code from the serial number.

This manual is applicable to:

- Production Batch: **AA** only
  - Example serial number: TT0120**AA**00001

### 2.2 What you will need

In order to deploy the NEON Temperature Transmitter, a compatible and operational LoRa-WAN network architecture is required. This manual does not contain any instructions of how-to setup and install LoRa-WAN networks. TWTG offers radio network planning and IT-architecture design services to fully integrate the products in the NEON product line.

### 2.3 What is in the box

When the product is delivered check the components for damage and if all box items mentioned below are included.

Box Items	
NEON Temperature Transmitter	2 batteries, included in the product 1 mounting bracket, mounted on the product 1 M12 connector dust cap, mounted on the product
Declaration of Conformity	Declaration of Conformity, containing a link to latest version of this product manual and other relevant product documentation

**Table 2:** Box Items

## 2.4 Product Specifications

Product	
Product name	TWTG NEON Temperature Transmitter
Type identification	DS-TT-01-01
Supported temperature sensors	Thermocouple Type-K (other types on request) RTD PT100 RTD PT1000 (on request)
Environmental conditions	
Ambient temperature range	-40°C - 80°C
Storage temperature range	10°C - 30°C
Water & dust resistance	IP65
Mechanical	
Material	Molded plastic
Weight (including mounting bracket)	245 g
Dimensions	100x70x45 mm
Installation	
Transmitter	Band clamp or bolts (not included)
Maximum cable length	Limited by equipment output parameters, see <a href="#">Selecting a thermocouple wire</a>
Certifications	
ATEX certificate number	DEKRA 20ATEX0098 X
IECEX certificate number	IECEX DEK 20.0056X
Ex marking	Ex II 2G Ex ib IIC T4 Gb
Applicable ATEX/IECEX standards	EN 60079-0 EN 60079-11
IMDA Dealer License	DA108442
CE	EN 300 220-1 EN 300 220-2 EN 300 330
Safety	EN 62368-1 EN 62311 EN 60529
EMC	EN 301 489-1 EN 301 489-3

**Table 3:** Product specifications. See also "NEON datasheet" in [Related documents](#) for a detailed overview of specifications.

Connectivity	
Protocol	LoRa-WAN
Frequency band	863-870 MHz
	902-928 MHz (compatible)
Maximum RF output power	+13 dBm
Provisioning	
QR / Serial number	Serial number (read only)
NFC	Serial number (read only)

**Table 4:** Product specifications. See also "NEON datasheet" in [Related documents](#) for a detailed overview of specifications.

## 2.5 Product Type Identification

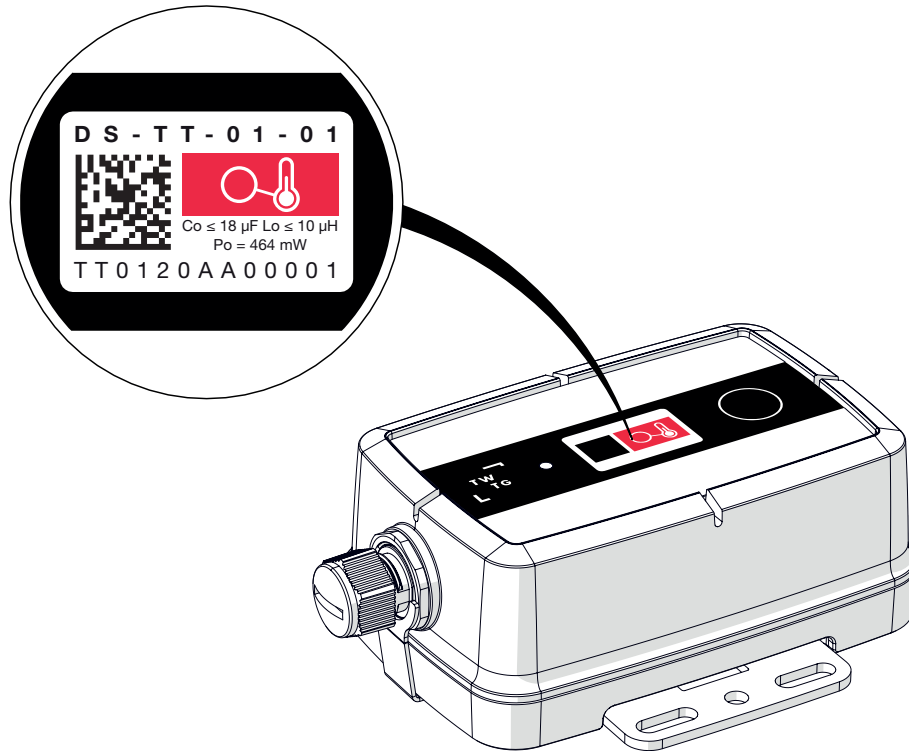

Figure 1: Example Drawing "Front Panel (EU)"

AA-BB-CC-DD	
AA - Product Family	DS
BB - Product Variant	TT = Temperature Transmitter
CC - Main Revision	Eg. 01
DD - Region	01 = Europe, 868

Table 5: Product Nomenclature

AABBCCDDEEEEE	
AA - Product Variant	TT = Temperature Transmitter
BB - Product Revision	Eg. 01
CC - Production Year	Eg. 20 = 2020
DD - Production Batch	Eg. AA, AB, AC, etc
EEEEEE - Serial Number	Eg. 00001

Table 6: Serial Number



## 2.6 Component Names

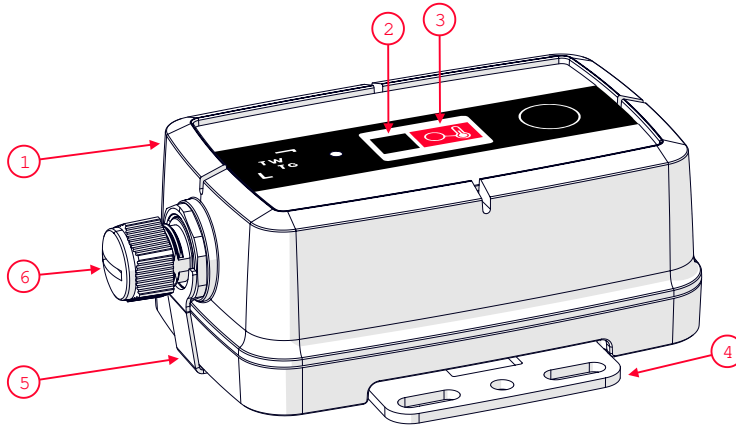

**Figure 2:** Component Names

Number	Description
1	Neon Transmitter
2	Data Matrix Code
3	NFC
4	Mounting Bracket
5	Earthing Bracket
6	M12 Connector Dust Cap

**Table 7:** Component Names

## 2.7 Product Dimensions

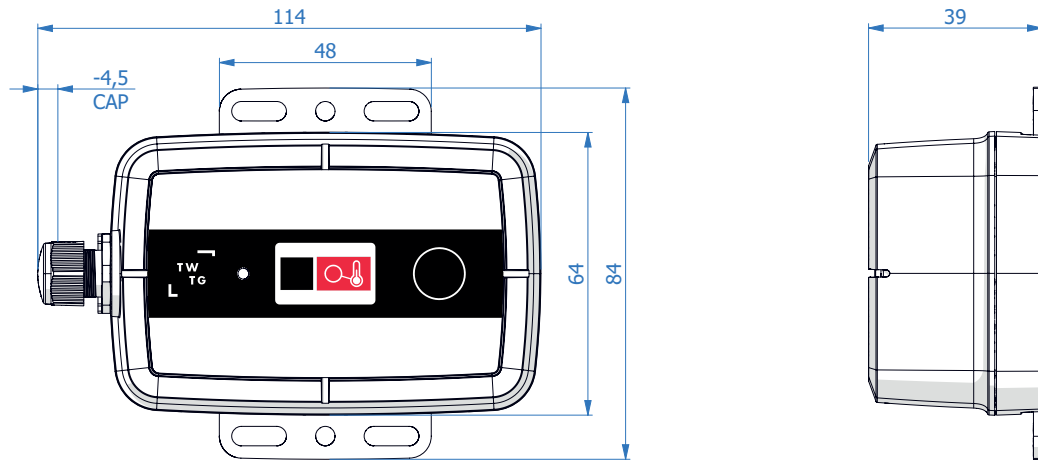

Figure 3: Neon Transmitter Dimensions (mm)

## 3 Warnings

### 3.1 ATEX / IECEx

#### 3.1.1 Specific Conditions of Use



#### **WARNING - POTENTIAL ELECTROSTATIC CHARGING HAZARD**

---

- The product shall be installed in such a way that the risk for electrostatic discharges is minimised;
  - When the equipment is used in hazardous locations, avoid any actions which generate electrostatic discharge;
    - Cleaning: The equipment shall only be cleaned using a wet cloth;
    - Installation: Touch non-metallic parts with an insulating object;
    - Environment: Do not use the product in environments with powerful charge generating processes.
- 

#### 3.1.2 Installation

- This equipment shall be installed according to NEN-EN-IEC 60079-14 and the installation instructions;
- This equipment is intended for fixed installations only;
- This equipment is intended for use in restricted access areas only .



#### **WARNING - DO NOT OPEN WHEN AN EXPLOSIVE ATMOSPHERE IS PRESENT**

---

- Under no circumstances shall the equipment enclosure be opened within a hazardous area
- 

#### 3.1.3 Operation

- The connector of this equipment shall not be connected when an explosive atmosphere is present;
- The thermocouple or RTD shall either be earthed or have an infallible isolation to earth with an dielectric strength of 500 VAC/1minute or greater;
- This equipment shall only be used in environments where electromagnetic field strength is limited according to NEN-EN-IEC 60079-14;
- This equipment is only intended for use in combination with NFC Forum Tag 2 Type technical specification compatible readers;
- This equipment shall only be used within ambient temperatures between -40 °C and +80 °C.

#### 3.1.4 Service

- This equipment shall only be opened by TWTG or by a competent instructed person;
  - The battery is serviceable by said persons;
  - Only replace the battery in a non-hazardous location;
  - Only use SAFT LS17500 batteries;
- If damage to the enclosure is evident, a trained and competent person shall be immediately informed, who shall remove the device from service as soon as possible;
- If the equipment is or has been in contact with chemical materials, clean it appropriately.

### 3.1.5 Output parameters

The maximum output parameters are limited by the NEON Transmitter. When selecting the temperature sensor to be used with the transmitter, the following values must be taken into account:

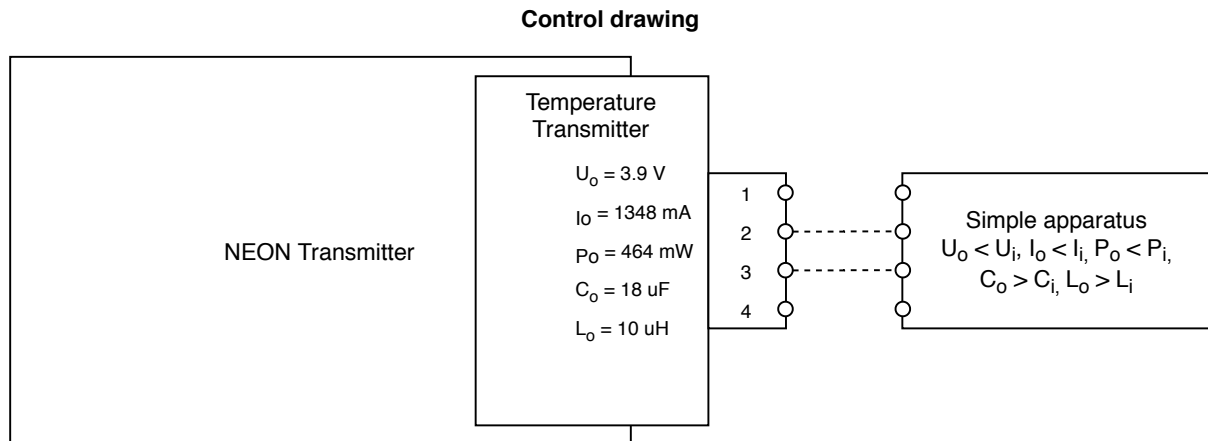

## 3.2 General

### 3.2.1 Transport and Storage

- The product must be kept in its original packaging until it reaches the installation site to prevent damage while in transit;
- The storage location must be dry;
- The product must not be exposed to vibrations or impact during storage.

### 3.2.2 Warranty

- The warranty covers the period noted on the quotation;
- If the device doesn't function as documented, the customer should contact TWTG and provide the following information;
  - Model specification;
  - Serial number;
  - Circumstances under which the problems developed;
  - Any previously generated data;
- The party responsible for the costs of solving the problem shall be determined by TWTG on the basis of an investigation conducted by TWTG.

### 3.2.3 Warranty will be void in case of

- Malfunction due to ignoring the design specifications;
- Malfunction due to modification of the product carried out by the user;
- Deferred maintenance of the product or the installation location.

## 4 Provisioning

### 4.1 User Interface

The product contains one Light Emitting Diode (LED) to communicate with the user. In order to interact with the device a button is present on the right side of the NFC label.

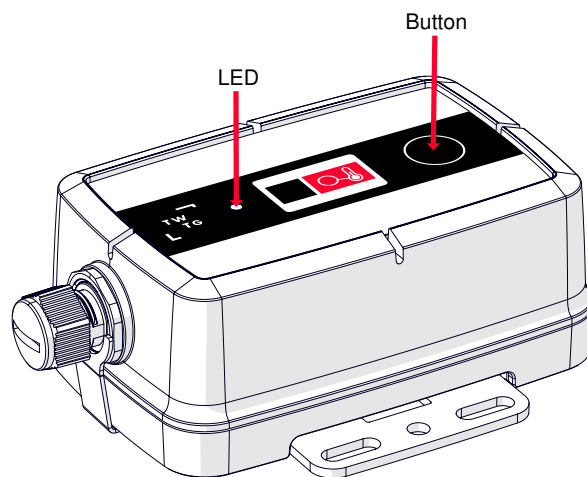

**Figure 5:** NEON Temperature Transmitter Interface

## 4.2 Operating the Device

### 4.2.1 Read device status

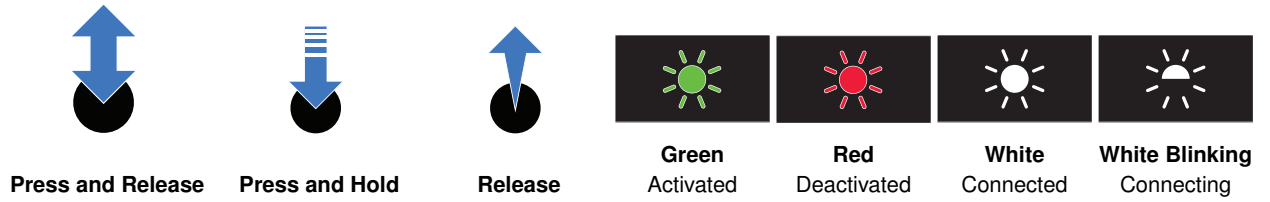

#### 1. Press and Release the button button:

- **2.1 Green:** Device is activated
- **2.2 Red:** Device is deactivated

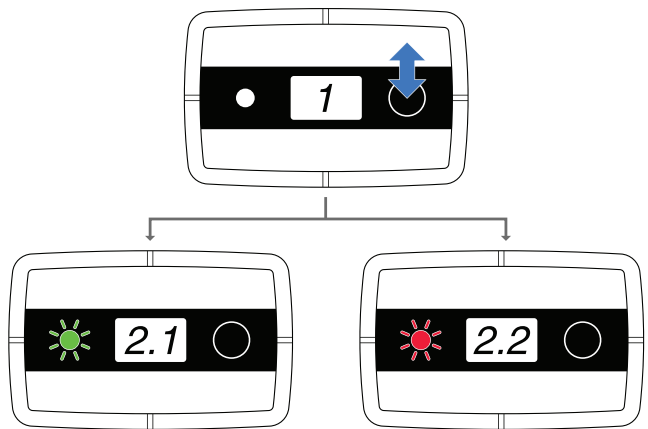

### 4.2.2 Device Activation

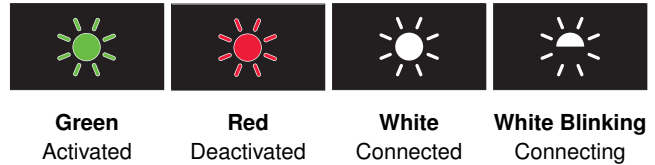
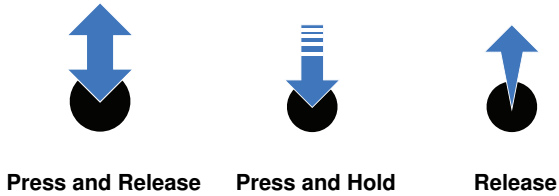

1. Press & hold the button and the device will immediately show it's status:

- 2.1 Red: Deactivated, or
- 2.2 Green: Already Activated

*Note: Release the button if it's already activated otherwise the deactivation procedure will start.*

3. Hold the button for 5 more seconds to start activation:

- 4. Blinking White: Connecting to the Network

5. Within a typical maximum of 3 minutes\* the device will show:

- 5.1 White: Sending activation message, or
- 5.2 Red: Network failure

6. Within a typical maximum of 3 minutes\* the device will show:

- 6.1 Green: Activation succeeded, or
- 6.2 Red: Network failure

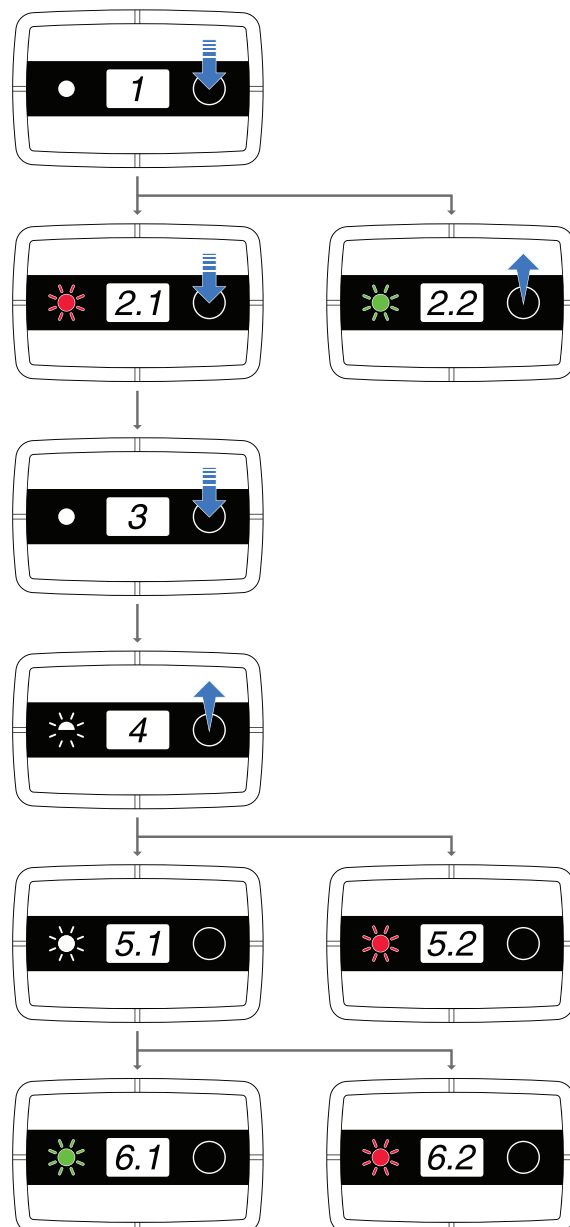

Notes:

- \*All timeout and retry values are valid for the default configuration, the maximum timeout might be longer when process is performed repeatedly due to RF duty cycle limitations.

### 4.2.3 Device Deactivation

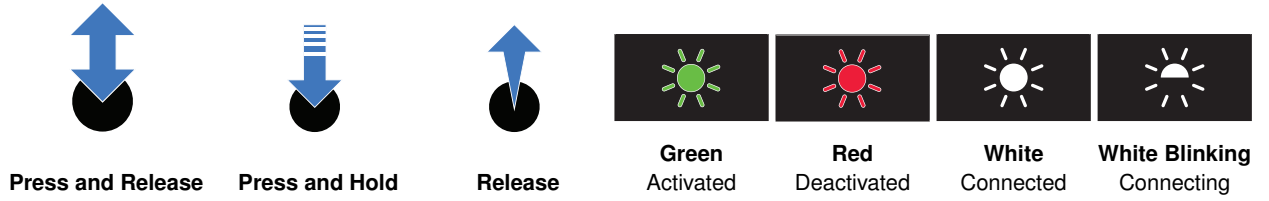

1. After holding the button for 5 seconds the device will show:

- 2.1 Green: Activated
- 2.2 Red: Already Deactivated, or

*Note: Release the button if it is already deactivated otherwise the activation procedure will start.*

Hold the button for 5 more seconds if the device is activated:

- 3. Red: Deactivation Succeeded

*NOTE: The deactivation procedure will always succeed. An attempt for sending a status message will be performed. This will not be shown as blinking white LED.*

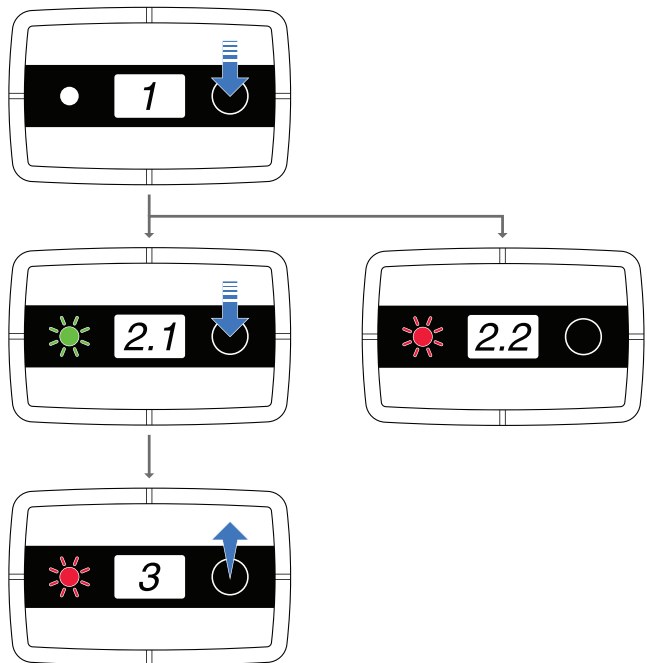



## 4.3 Product Identification

### 4.3.1 NFC

The NFC label is located in the identification sticker and programmed with the serial number of the device. The serial number read from the NFC can be used as unique identifier for provisioning and registration.

### 4.3.2 Data Matrix Code Code

The Data Matrix Code label also represents the serial number of the device. The serial number read from the QR code can be used as unique identifier for provisioning and registration.

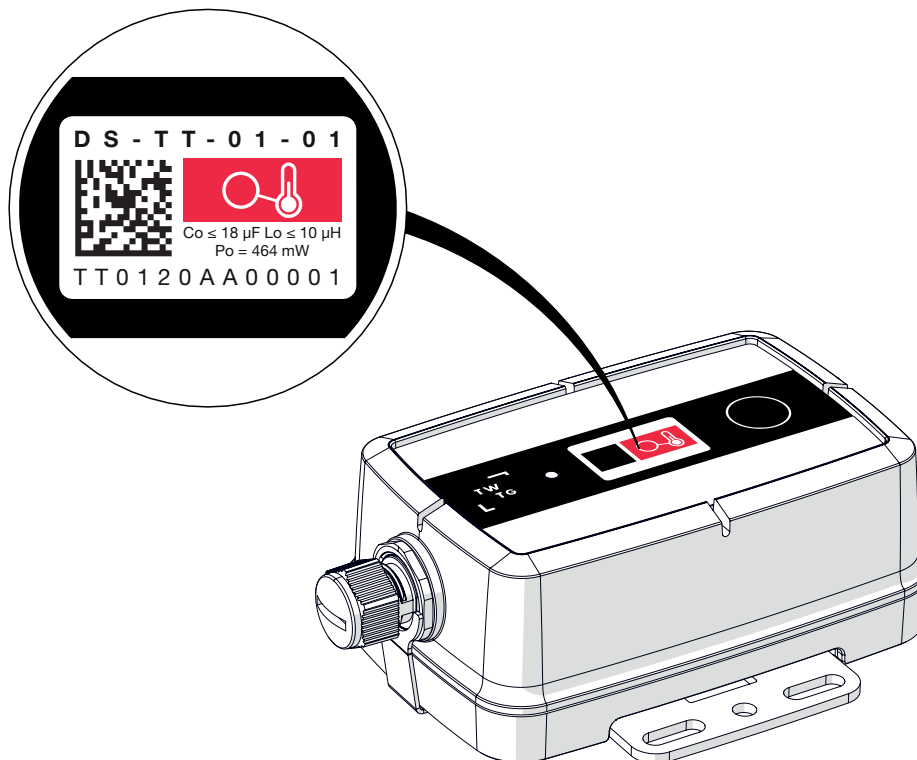

**Figure 6:** NFC and Data Matrix Code code Location

See [Serial Number](#) for the a detailed label description.

## 5 Installation

### 5.1 Precautions

#### WARNING

- Avoid placing wiring close to noise sources such as large motors or power supplies;
- Only connect the M12 connector to the Temperature Transmitter when there is no explosive atmosphere present;
- The equipment must be installed in accordance with EN 60079-14.

### 5.2 Mounting Bracket Dimensions

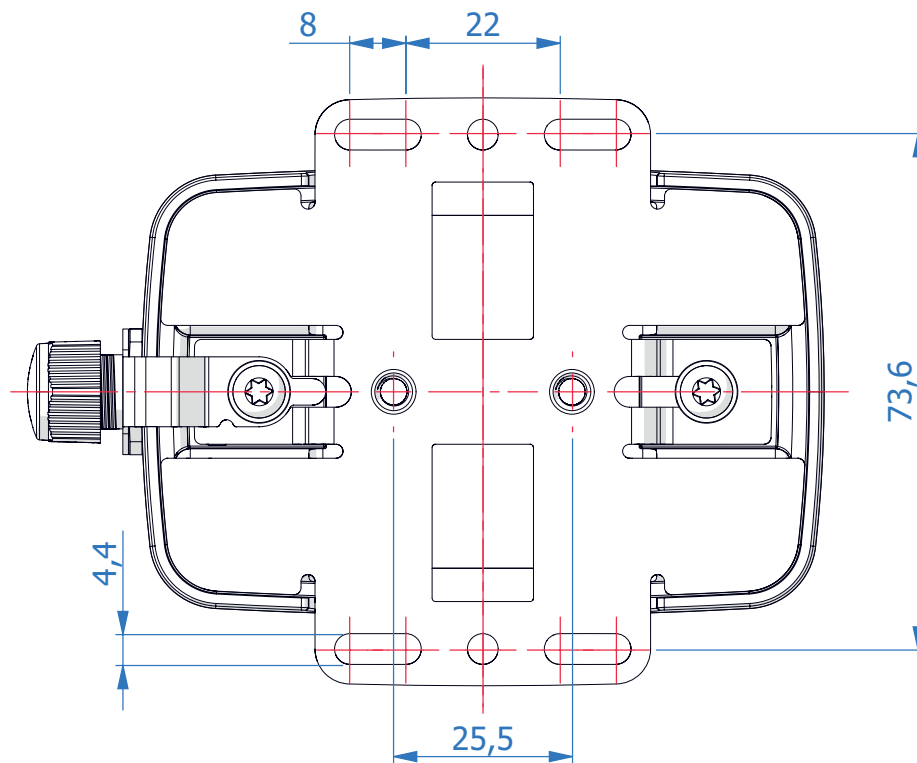

Figure 7: Product Dimensions

### 5.3 Installation Methods

#### 5.3.1 Installation using mounting holes

Place the bracket against the (flat) desired surface and use the screw holes or slots to fix in place.  
 Note: Slots and screw holes are designed for M4 fasteners.

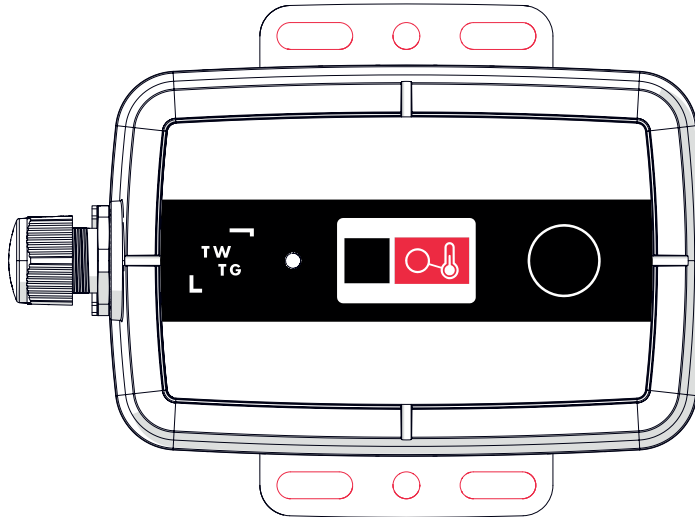

Figure 8: Product Mounting Holes

#### 5.3.2 Installation using threaded holes

Note: Threaded hole accepts M5 bolts.

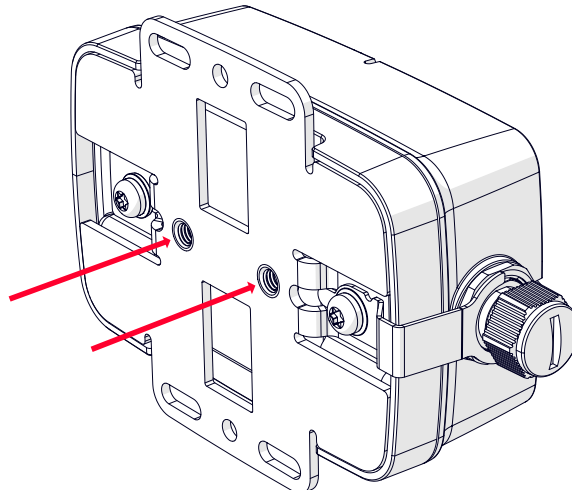

Figure 9: Product Threaded Mounting Holes

### 5.3.3 Installation using bandclamp

The Neon Temperature Transmitter can be mounted to a pole using a 14 mm wide band clamp, other sizes are not recommended.

**Procedure:**

1. Place the band clamp through the bracket;
2. Place the band clamp around the pole and cut to size;
3. Place the band clamp through the adjustable tightener and fold around the bottom with a plier;
4. Place the band clamp around the pole with the (adjustable) tightener and fix it in place.

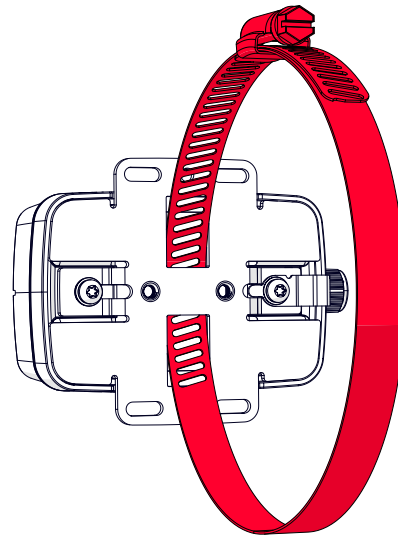

**Figure 10:** Installation using bandclamp

## 5.4 Using the Temperature Transmitter with Thermocouples

### 5.4.1 Cold Junction Compensation

The interface to the NEON Temperature Transmitter uses an M12 connector with Type-A polarisation.

This interface can be used for reading out both thermocouples and RTDs.

For use with thermocouples the Temperature Transmitter has a built-in cold junction compensation (CJC):

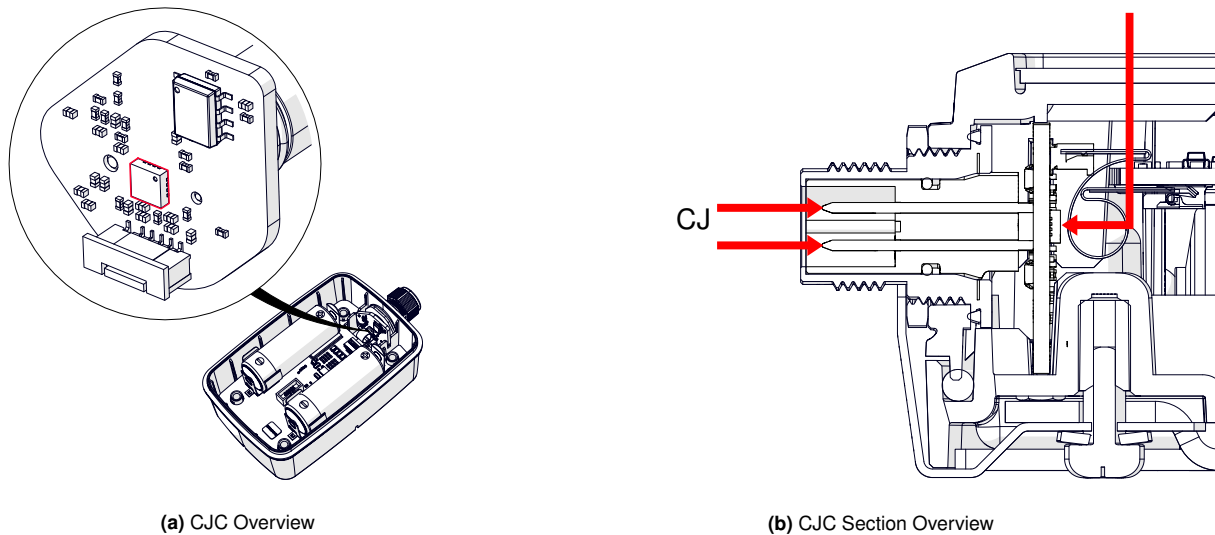

**Figure 11:** Cold Junction Compensation

The temperature transmitter uses the copper pins of the M12 connector as the cold junction, as seen in figure 11. [Cold Junction Compensation](#). The cold junction compensation uses the temperature of the copper contacts as measured by the internal reference temperature sensor. The internal reference temperature is directly in thermal contact with the cold junction.

### 5.4.2 Assessed connectors

The following connectors have been assessed by TW TG and can be used in combination with the Neon Transmitter:

Manufacturer	Part Number	Type
Phoenix Contact	1424656	Push-in, metal, right angle (female) connector
Phoenix Contact	1424655	Push-in, metal, straight (female) connector

**Table 8:** Compatible M12 connectors

### 5.4.3 Selecting a thermocouple wire

A suitable thermocouple wire needs to be assessed as simple apparatus and needs to be assessed as safe with regards to thermal and spark ignition.

Select a cable with cross section of  $0.14\text{mm}^2$  to  $0.75\text{mm}^2$  with a round outer shell with a diameter of 4 to 8 mm. If the sensor is mounted in a noisy environment a shielded cable can be used.

### WARNING

- Do not connect the shield to the M12 connector shield to prevent a multi-point ground, only connect the shield at the thermocouple junction.

Use the values as listed in table 9 to determine compliance. The maximum permitted cable length is determined by cable  $L_i$  and  $C_i$  and limited to the maximum installation cable length of 3 meters.

Limiting Value	Thermocouple wire requirements
$C_o$	$18 \mu F$ $C_i < C_o$
$L_o$	$10 \mu H$ $L_i < L_o$
$P_o$	Assess heat-up of cable with $P_o$ and $U_o$ parameters for all lengths between 0 meter and required cable length
$U_o$	Assess heat-up of cable with $P_o$ and $U_o$ parameters for all lengths between 0 meter and required cable length

Table 9: Thermocouple limiting values

#### 5.4.4 Connecting a thermocouple wire to the temperature interface

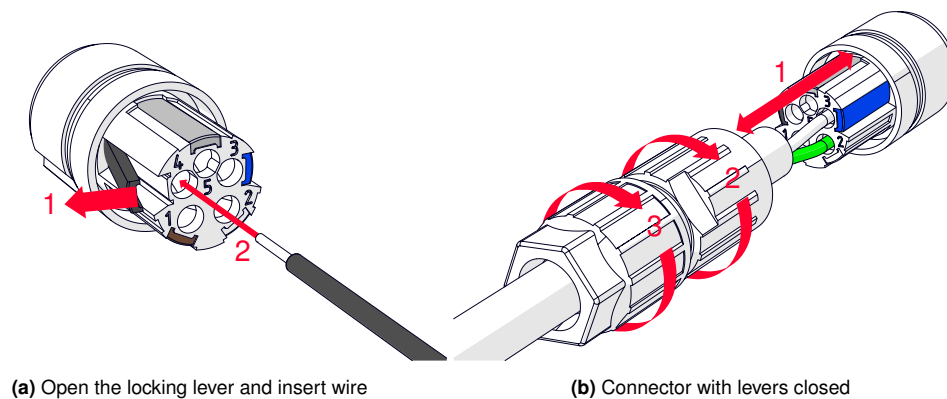

Figure 12: Cable connection example

Pin	Connection
Pin 1	Not used
Pin 2	Thermocouple Positive Connection
Pin 3	Thermocouple Negative Connection
Pin 4	Not used

Table 10: Thermocouple pinout

- Strip the wires down by 7mm;
- Insert the cable through the waterproofing O-Ring and cable gland nut;
- Open the locking lever of the push in connector;
- Press the thermocouple wire in the connector, use table. 10 to verify polarity. Do not use excessive force;
  - Ensure the correct polarity, as the device will not function properly with reversed polarity;

5. Close the locking lever of the push in connector;
6. Tighten the nut with the O-Ring.

## 5.5 Using the Temperature Transmitter with a RTD (3-wire)

The Temperature Transmitter can be used in combination with a 3-wire RTD. To do so, the default configuration of the device needs to be changed. See "Communication Protocol" in [Related documents](#).

### 5.5.1 Connecting a RTD (3-wire) sensor to the temperature interface

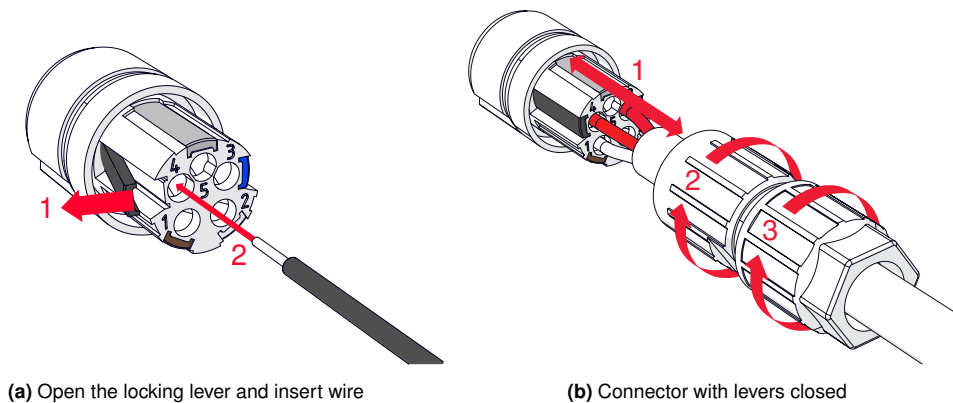

Figure 13: Cable connection example

Pin	Connection
Pin 1	RTD - (white)
Pin 2	Not used
Pin 3	RTD Sense (red)
Pin 4	RTD + (red)

Table 11: RTD pinout

1. Strip the wires down by 7mm;
2. Insert the cable through the waterproofing O-Ring and cable gland nut;
3. Open the locking lever of the push in connector;
4. Press the RTD wire in the connector, use table. 11 to verify polarity. Do not use excessive force;
  - Ensure the correct polarity, as the device will not function properly with reversed polarity;
5. Close the locking lever of the push in connector;
6. Tighten the nut with the O-Ring.

## 6 Product Functionalities

A detailed description of setting-up communication and configuring device settings can be found in "Communication protocol", refer to table 1. [Related documents](#).

### 6.1 Application Event Message

The temperature transmitter measures and reports the temperature either by set intervals (a timer-based trigger) or a condition-based trigger.

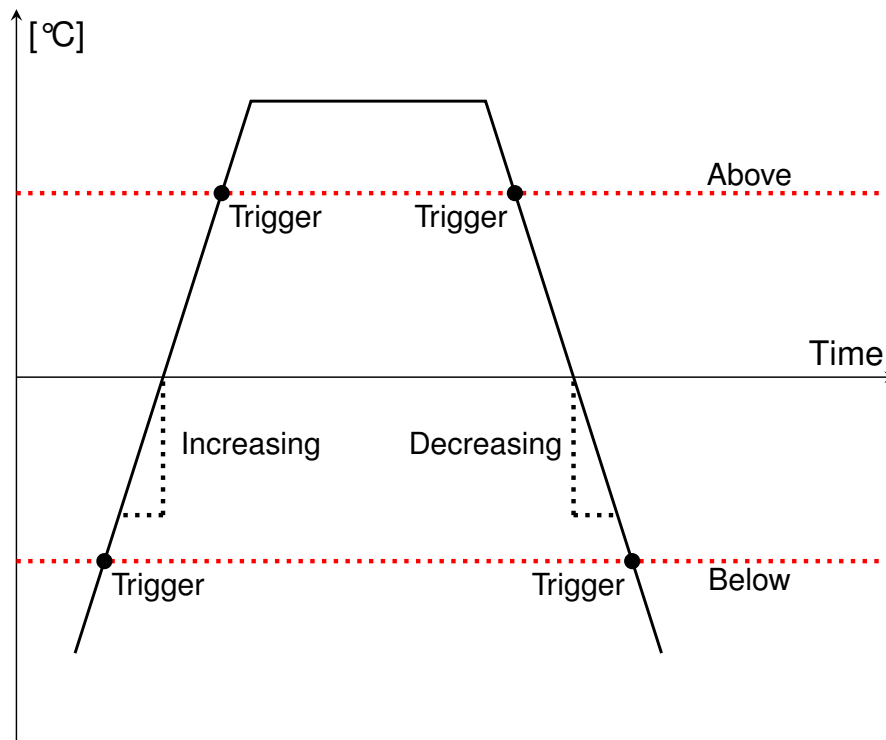

Figure 14: Application trigger event message

#### 6.1.1 Event-triggers

Event-messages are triggered on one of the following triggers.

- **Timer (periodic):**

The timer trigger is configurable through the following configurations:

- *temperature\_measurement\_interval\_seconds*  
Interval in seconds, at which the temperature sensor is read.
- *periodic\_event\_message\_interval*  
Interval in the number of measurements at which the application event messages are periodically sent. The periodic counter is reset on every event message.

- **Condition:**

A condition-based trigger can be either of the following triggers:

- *Above*  
If the maximum temperature is above the *temperature\_threshold* then the condition is true. A transition of the condition from false to true or true to false will trigger an event message.
- *Below*



If the minimum temperature is below the `temperature_threshold` then the condition is true. A transition of the condition from false to true or true to false will trigger an event message.

– *Increasing*

The condition is true when the current temperature is at least `temperature_threshold` higher than the minimum temperature in the `measurement_window` (The maximum number of measurements to observe delta temperature to trigger an event). A transition of the condition from false to true or true to false will trigger an event message.

– *Decreasing*

The condition is true when the current temperature is at least `temperature_threshold` lower than the maximum temperature in the `measurement_window` (The maximum number of measurements to observe delta temperature to trigger an event). A transition of the condition from false to true or true to false will trigger an event message.

### 6.1.2 Content application event message

- **Temperature**

The connected sensor temperature in units of 0.1 °C:

- Maximal;
- Average;
- Minimal.

- **Trigger**

Source of the trigger for the application event message:

- "timer" (0);
- "condition\_0" (1);
- "condition\_1" (2);
- "condition\_2" (3);
- "condition\_3" (4).

- **condition\_n**

The current state of each condition.

## 6.2 Device Status

Besides reporting the application temperature as discussed previously, the Temperature Transmitter also reports on the device status itself. This is done through a device status messages. A device status message is sent periodically and includes a range of device health parameters, including the following:

- `event_counter`;
- `battery_voltage`;
- PCB temperature;
- `tx_counter`;
- `avg_rssi`;
- `avg_snr`.

See "Communication Protocol" in [Related documents](#) for a detailed explanation.

## 6.3 Default Configuration

The Temperature Transmitter is delivered with a default configuration. The default configuration includes:

- Measurement interval of 15 mins;
- Event-based message at the time of each periodic trigger with an interval of 15 measurements. (15 \* 15 = 225 mins);
- Device status message interval of 24 hours;
- Enabled confirmation message on all messages.

See "Communication Protocol" in [Related documents](#) for a detailed explanation of all default configuration values.

## 7 Maintenance

### 7.1 Battery Replacement

The battery can be replaced using the battery replacement kit. See [Accessories & Spare Parts](#). This kit consists of the following parts:

- 2X SAFT LS-17500 battery
- 4X O-Ring
- 1X Gasket

#### 7.1.1 Battery Specifications

Specifications	
Manufacturer	Saft
Part number	LS-17500
Quantity	2
Battery Type / Size	Type A
Chemistry	Lithium Thionyl Chloride
Terminal Type	Standard
Dimensions	50.9 x 17.13 mm
Battery Life	>10 years*

**Table 12:** Battery Specifications

*\*Note: Applicable to default configuration. Battery lifetime depends on average ambient temperature, network quality and device configuration.*



**WARNING - Only use the battery as specified in table 12. [Battery Specifications](#)**

#### 7.1.2 Required tools

- Torque screwdriver with TX20 bit;
  - See [Assembly of device](#) for torque settings;
- Loctite 243;
- ESD strap.



**IMPORTANT: ESD Sensitive Electronics**

The product shall be installed in such a way that the risk for electrostatic discharges is minimised.

- Take proper precaution such as a grounded wrist strap and avoid touching the electronics board

### 7.1.3 Disassembly of device



## WARNING - DO NOT OPEN WHEN AN EXPLOSIVE ATMOSPHERE IS PRESENT

- This equipment shall only be opened by TWTG or by a competent instructed person;
  - The battery is serviceable by said persons;
  - Only use SAFT LS17500 batteries.

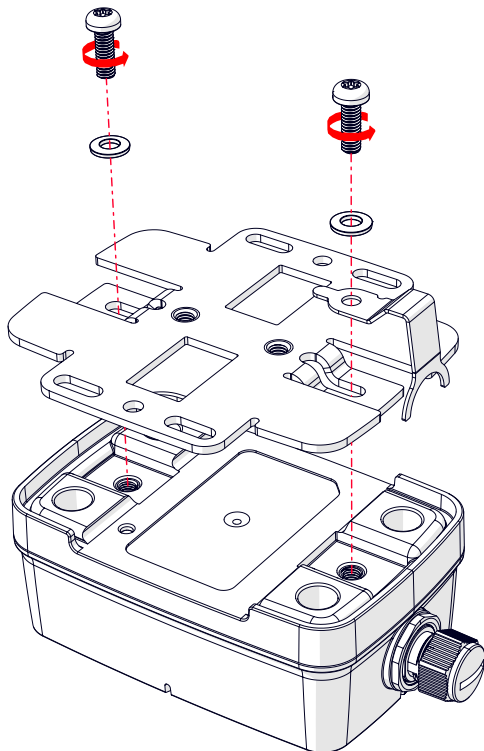

**Step 1:** Remove the two M4 screws and washers fixing the bracket

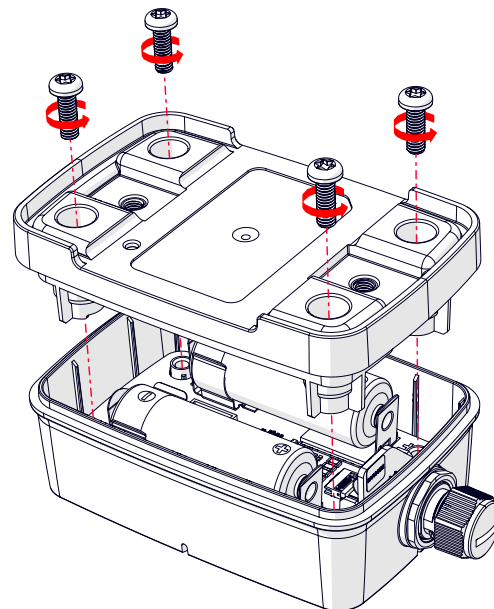

**Step 2:** Remove the four screws and remove the lower housing

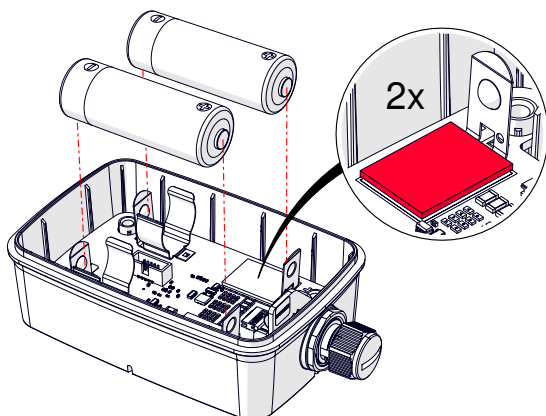

**Step 3:** Remove the batteries, inspect presence of insulating pads, marked in red

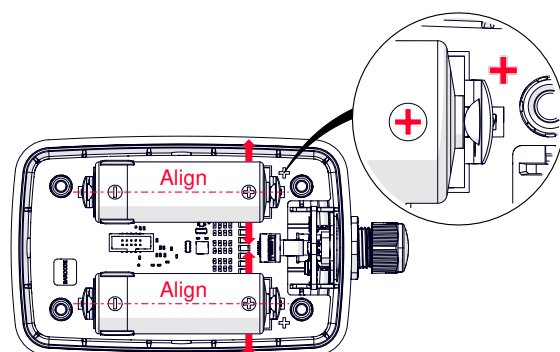

**Step 4:** Place the two new batteries in the battery holder with the positive side facing the positive markings on the circuit board

### 7.1.4 Built in Self-Test Procedure

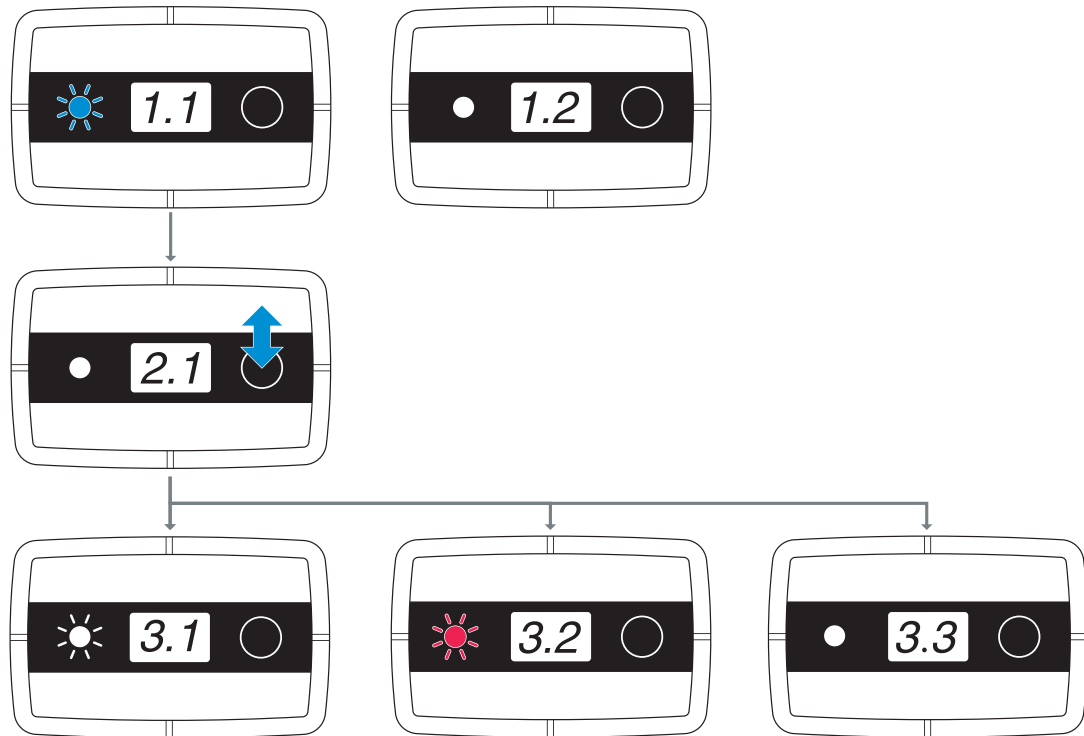

**Figure 15:** Built-in self-test

**1:** After successful replacement of the battery the device will go into self test mode. This mode is activated for 30 seconds;

**1.1:** A BLUE LED will show after inserting the battery;

**1.2:** If no LED is shown, check the battery and / or device;

**2:** Start the test;

**2.1:** Press and Release the button;

**3:** Test Results;

**3.1:** LED turns bright WHITE for 5 seconds. Self test passed;

**3.2:** LED turns RED, self test failed. Check device;

**3.3:** No LED, no response from device. Check device.

After pressing the button once and passing the self-test the device will leave the self-test mode. Pressing the button again will show the device status, as explained in [Read device status](#).

### 7.1.5 Assembly of device

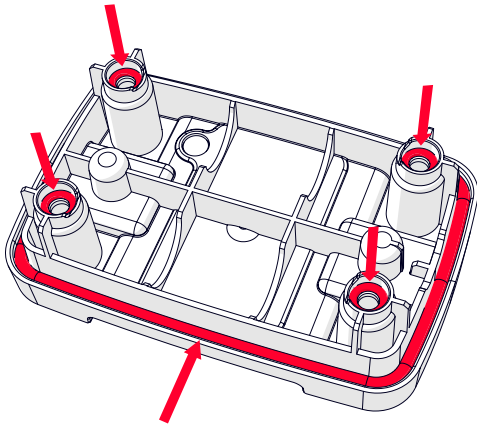

**Step 5:** Replace the 4 O-Rings surrounding the screws and the gasket in the outer edge of the enclosure

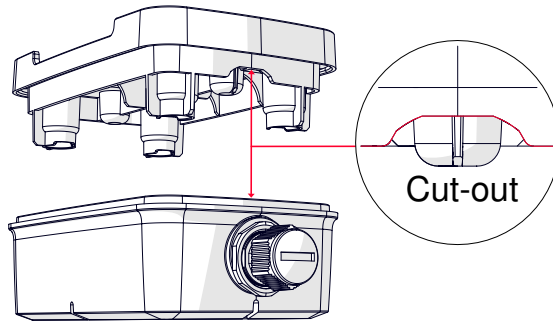

**Step 6:** Place the lower housing back on the upper housing. Please see make sure that the cutout on the lower housing matches the upper housing. Tighten the four screws to fix the lower housing

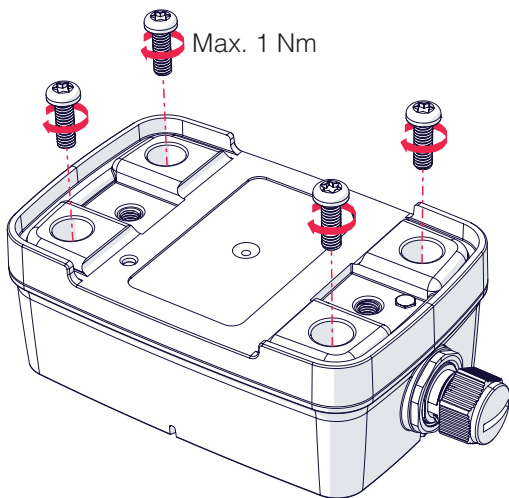

**Step 7:** Tighten the four M4 screws to fix the lower housing

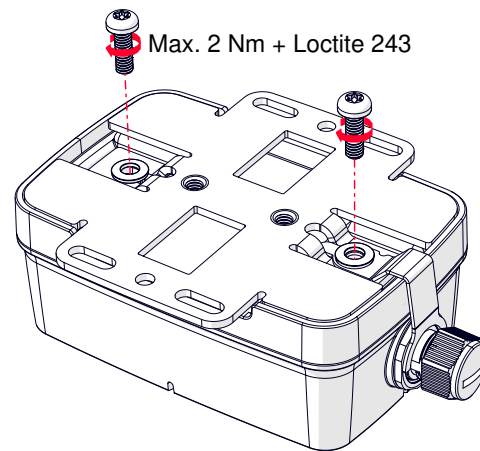

**Step 8:** Tighten the two M4 screws and washers to fix the bracket. Make sure to attach the earthing bracket.

 **WARNING - Ensure proper connection of the earthing bracket**

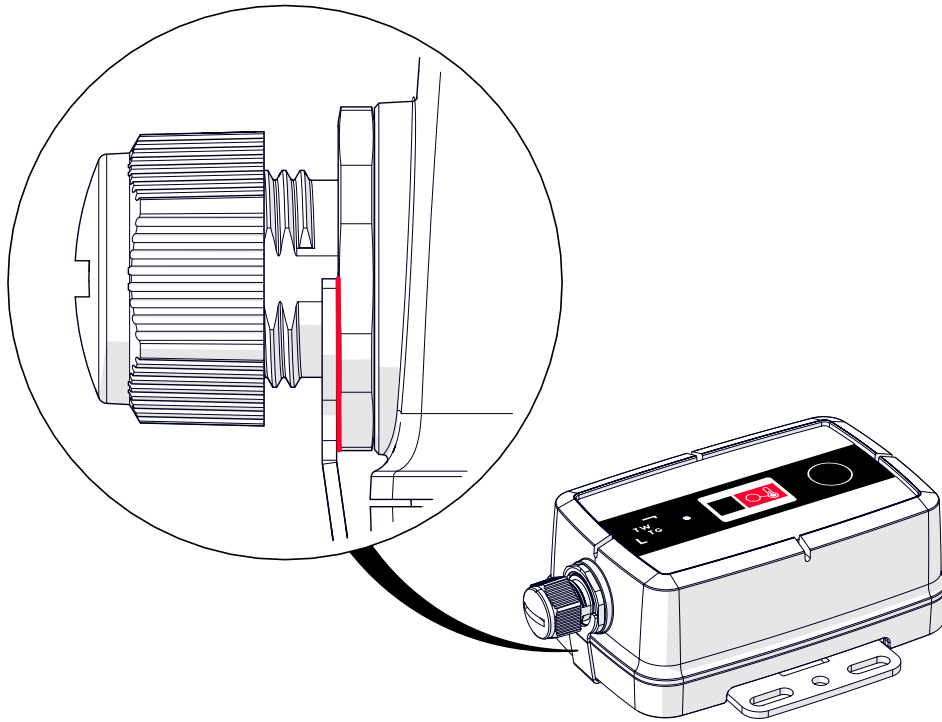

**Step 9:** The bracket must touch the M12 connector

## 8 Accessories & Spare Parts

Type	Order code	Description
Battery Replacement Kit	5029_P20-002_Battery- Replacement-Kit	Including two batteries, 4 O-Rings, 1 gasket
M12 compatible connector	Phoenix 1424655	Contact Push-in, metal, straight connector
M12 compatible angled connector	Phoenix 1424656	Contact Push-in, metal, right angle connector

**Table 13:** Available Accessoires & Spare Parts

---

## 9 Declaration of Conformity

This product complies with the following standards:

1. ATEX Directive (2014/34/EU):
  - EN 60079-0:2012 +A11:2013
  - EN 60079-0:2018
  - EN 60079-11:2012
2. Radio Equipment Directive (2014/53/EU):
  - EN 300 220-1 V3.1.1
  - EN 300 220-2 V3.1.1
  - EN 300 330 V2.1.1
  - Draft EN 301 489-1 V2.2.0
  - Draft EN 301 489-3 V2.1.1
  - EN 60529
  - EN 62311:2018
  - EN 62368-1:2014
3. WEEE Directive 2003/1008/EC
4. RoHS (2011/65/EU)

For the full Declaration of Conformity see:

*[www.twtg.io/legal](http://www.twtg.io/legal)*



## Revision

## History

Revision	Date	Author(s)	Description
A1	10-12-2020	SW, WK	Concept version
B	05-03-2020	SW, WK, JP, KH, TB	First Release
B1	18-03-2020	WK	Corrected Thermocouple polarity Removed duplicate "Product Nomenclature" table
B2	07-04-2021	WK	Updated RTD pinout to 3-pin Updated accessories
C	07-04-2021	WK	Updated version to C
C1	07-07-2021	WK	Added declaration of conformity Added expected battery life Updated battery replacement UI Updated serial number explanation Added batchcode compatibility
C2	17-08-2021	WK	Updated batch code information Updated deactivation user interface flow
D	06-09-2021	WK	Release of version D
D1	13-10-2021	WK	Added EN 300 330 Added EN 60529 Added IMDA dealer license number
E	07-04-2022	WK	Release of version E



**thermo-electra**  
temperature sensor solutions

Thermo Electra B.V.  
Weteringweg 10  
2641KM Pijnacker  
The Netherlands

Phone +31 (0)15 - 3621200  
Fax +31 (0)15 - 3694082  
Email [sales@thermo-electra.com](mailto:sales@thermo-electra.com)  
<http://www.thermo-electra.com>

