



- Suitable for hazardous areas, Zone 0, 1 and 2 (gas), and Zone 20, 21 and 22 (dust), with a suitable Intrinsically Safe isolator
- Temperature range: -20°C to 1000°C
- Two wire, 4-20 mA output
- Rescalable output and adjustable emissivity setting via optional USB and RS-485 adapters
- Fast response time and high stability
- Stainless steel 316 housing - ideal for offshore applications
- IP65 sealed
- Supplied with up to 25 m cable

General Specifications	
Temperature range	See table of Model Numbers
Maximum Temperature Span	1000°C
Minimum Temperature Span	100°C
Output	4 to 20 mA
Field of View	See table of Model Numbers
Accuracy	± 1°C or 1%, whichever is greater
Repeatability	± 0.5°C or 0.5%, whichever is greater
Emissivity Setting Range	0.20 to 1.00 (pre-set to 0.95)
Emissivity Setting Method	Configurable via optional adapters
Response Time	240 ms (90% response)
Spectral Range	8 to 14 µm
Supply Voltage	12 to 24 V DC ± 5%
Maximum Current Draw	25 mA
Maximum Loop Impedance	See Application Guide (available separately)
Mechanical	
Construction	Stainless Steel 316
Major Dimensions	Ø 20 x length 150 mm (see Dimensions)
Mounting	M20 x 1.5 mm thread, length 46 mm, supplied with two mounting nuts
Cable Length	5 m, 10 m or 25 m as standard (contact Calex for information on extending the cable)
Weight with 5 m Cable	475 g

Environmental	
Environmental Rating	IP65 (NEMA 4)
Ambient Temperature Range	0°C to 70°C (Operating range)
Ambient Pressure Range	80 kPa (0.8 bar) to 110 kPa (1.1 bar)
Relative Humidity	Max. 95% non-condensing
CE Marked	Yes
RoHS Compliant	Yes

Hazardous Area Classification	
The ExTemp is ATEX, IECEX, TIIS and UKCA Ex (UKEX) certified.	
ATEX Classification	Ex II 1GD
IECEX Classification (Gas)	Ex ia IIC T4 Ga
IECEX Classification (Dust)	Ex ia IIC T135°C IP65 Da
Ambient Temperature Rating	-20°C ≤ Ta ≤ 70°C
Maximum DC Input Voltage	Ui = 28 V
Maximum Input Current	Ii = 93 mA
Maximum Input Power	Pi = 650 mW
Maximum Internal Capacitance	Ci = 8 nF
Maximum Internal Inductance	Li = 0 mH
ATEX Certificate Number	CML 14ATEX2079
IECEX Certificate Number	IECEX CML 14.0032
TIIS Certificate Number	TC21097
UKCA Certificate Number	CML 21UKEX2001

### OPTICS Diameter of target spot measured versus distance from sensing head (90% energy)

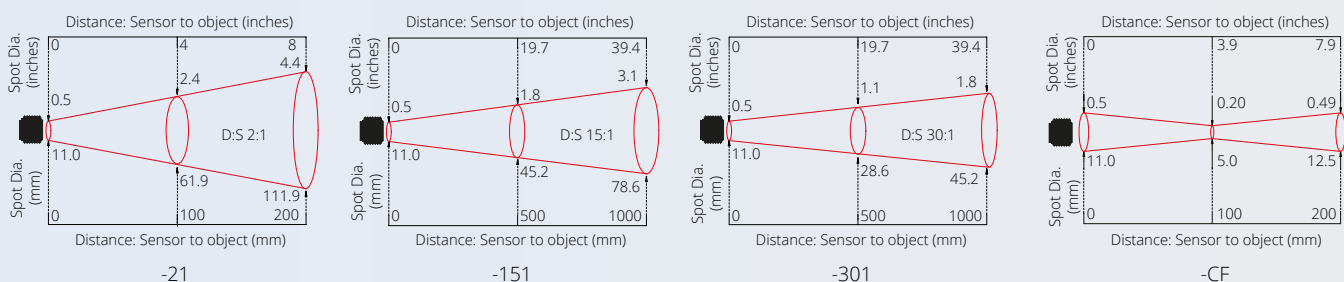

Note: The sensor will measure at longer distances than shown, with a larger measured spot diameter. Contact Calex for more information.

## CONNECTIONS: EXTEMP SENSOR

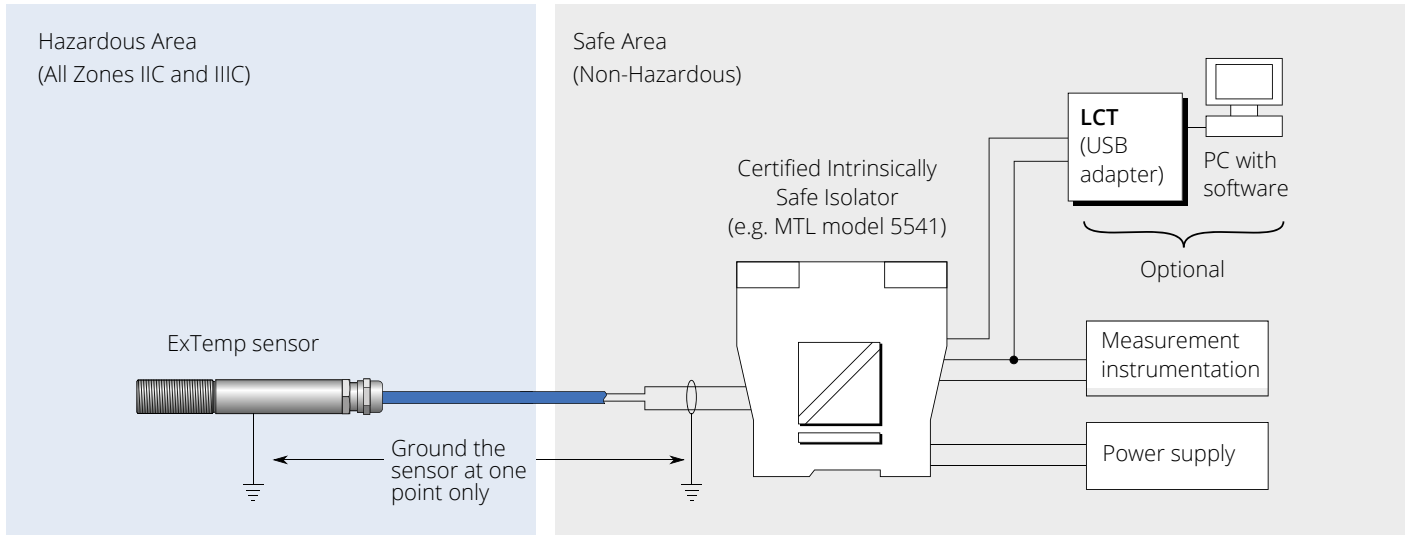

### CONFIGURATION

A choice of optional adapters is available to allow configuration of the ExTemp sensor.

**Both adapters must be connected on the safe side of an Intrinsically Safe barrier or isolator.** The barrier or isolator must be capable of digital communications over 4-20 mA, and correct loop polarity must be observed.

Configurable settings include the emissivity setting, 4-20 mA temperature range, averaging, peak and valley hold processing and reflected energy compensation.

### LCT

The Loop Configuration Tool (LCT) allows the ExTemp sensor to be connected to a PC via USB.

CalexConfig software makes it easy to configure the sensor.

For more information on the software, please see [www.calex.co.uk/software](http://www.calex.co.uk/software) and the Software data sheet.



### LCT-485 NETWORK INTERFACE

This DIN rail-mounted unit provides RS-485 Modbus RTU Slave communications for one ExTemp sensor. It allows up to 224 ExTemp sensors to be connected together in a network.

#### FEATURES

- Fault-tolerant RS-485 interface with up to 60 V over-voltage protection
- Isolated RS-485 interface for easy connection to separately powered buses
- Built-in 270 ohm loop resistor for simplified wiring

#### SPECIFICATIONS

<b>Mounting</b>	DIN rail (35 mm)
<b>Dimensions</b>	114(d) x 18(w) x 107(h) mm approx
<b>Connections</b>	Screw terminals for RS-485, power, and sensor loop
<b>Supply voltage</b>	6 to 28 V DC
<b>Max current draw</b>	50 mA
<b>Protocol</b>	Modbus RTU Slave
<b>Baud rate</b>	1200-57600 bps, detected automatically
<b>Ambient temperature</b>	-20°C to 70°C
<b>EMC Conformity</b>	BS EN 61326-1:2013 & EN 61326-2-3:2013*
<b>Max. No. of Devices</b>	Up to 224 x LCT-485 Slave devices per Modbus Master

\* for lines  $\leq$  30 m within buildings, for RS-485 & loop terminals



## NETWORK LAYOUT: LCT-485 INTERFACE

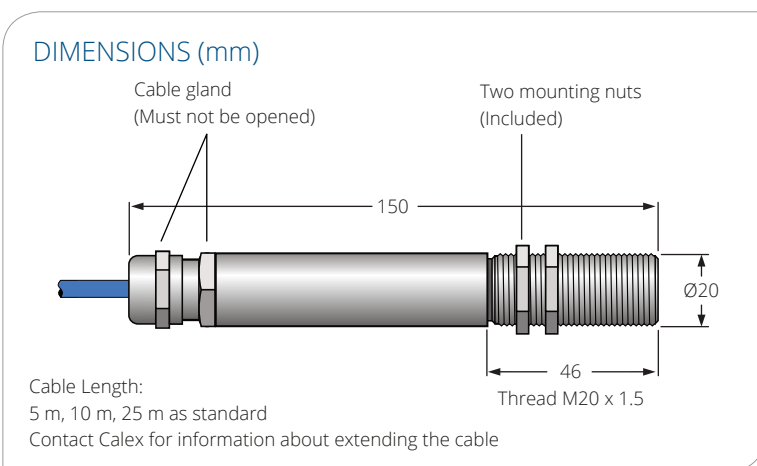
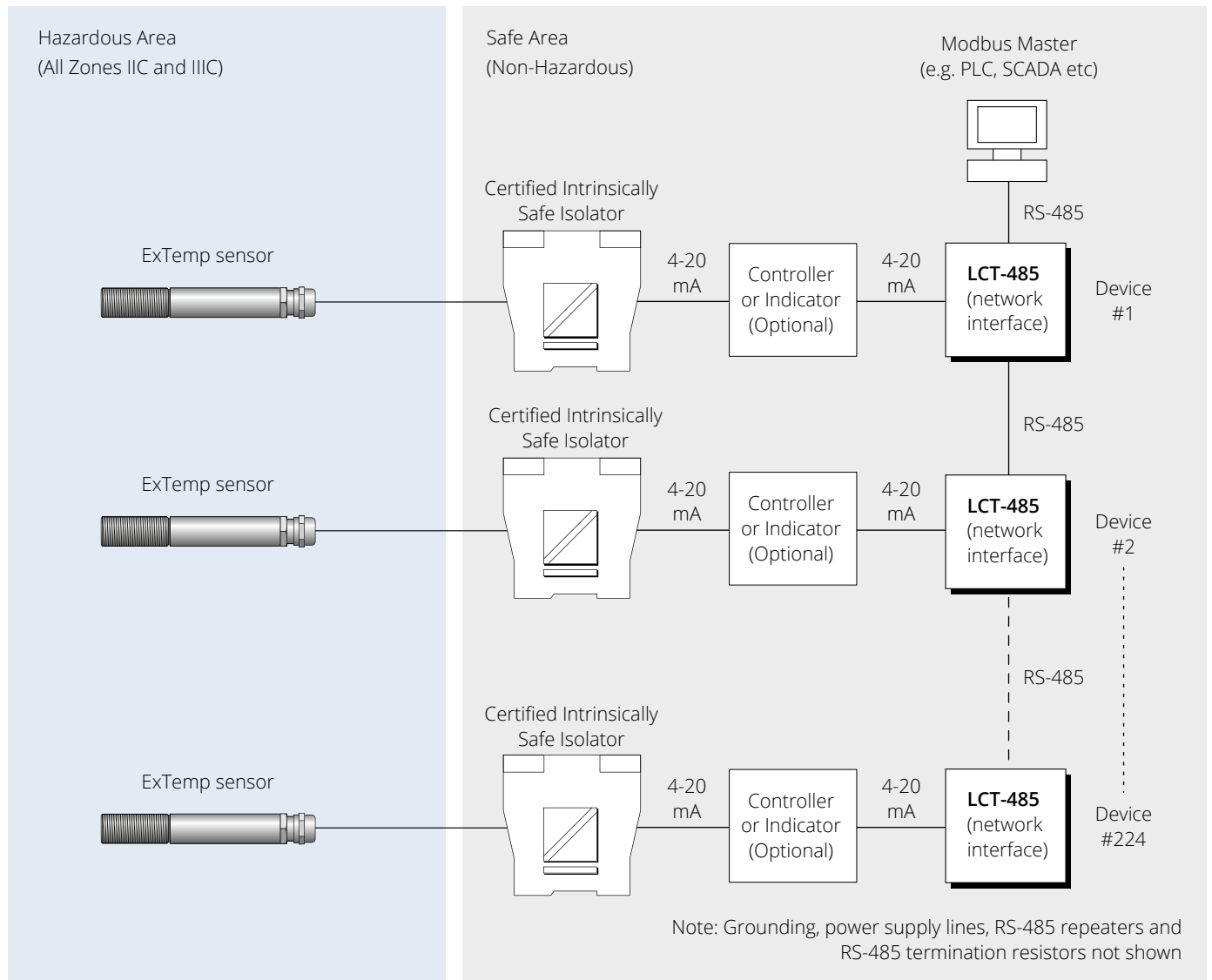

## MODEL NUMBERS

EX - 151 - LT - C - 25



### Cable Length

5 = 5 m  
10 = 10 m  
25 = 25 m

Contact Caalex for information regarding extending the cable

### User Configurable

C = Configurable via optional adapters

### Temperature Range

LT = -20°C to 100°C  
MT = 0°C to 250°C  
HT = 0°C to 500°C  
XT = 0°C to 1000°C  
ST = Special temperature range

On all models, temperature range may be rescaled between limits -20°C and 1000°C via optional adapters and software

### Field of View

21 = 2:1 divergent optics  
151 = 15:1 divergent optics  
301 = 30:1 divergent optics  
CF = Close focus optics  
(Spot Ø 5 mm at distance 100 mm)

## ACCESSORIES

<b>FBL</b>	Fixed mounting bracket (1-axis rotation)
<b>ABL</b>	Adjustable mounting bracket (2-axis rotation)
<b>APM</b>	Air purge collar (for 15:1, 30:1, Close Focus optics)
<b>APMW</b>	Air purge collar (for 2:1 optics)
<b>CALCERTA</b>	Calibration certificate, 3 temperature points, UKAS traceable
<b>LCT</b>	USB configuration adapter (CaalexConfig software available as a free download)
<b>LCT-485</b>	RS-485 Modbus network interface



**thermo-electra**  
temperature sensor solutions

Thermo Electra B.V.  
Weteringweg 10  
2641KM Pijnacker  
The Netherlands

Phone +31 (0)15 - 3621200  
Fax +31 (0)15 - 3694082  
Email sales@thermo-electra.com  
http://www.thermo-electra.com

